

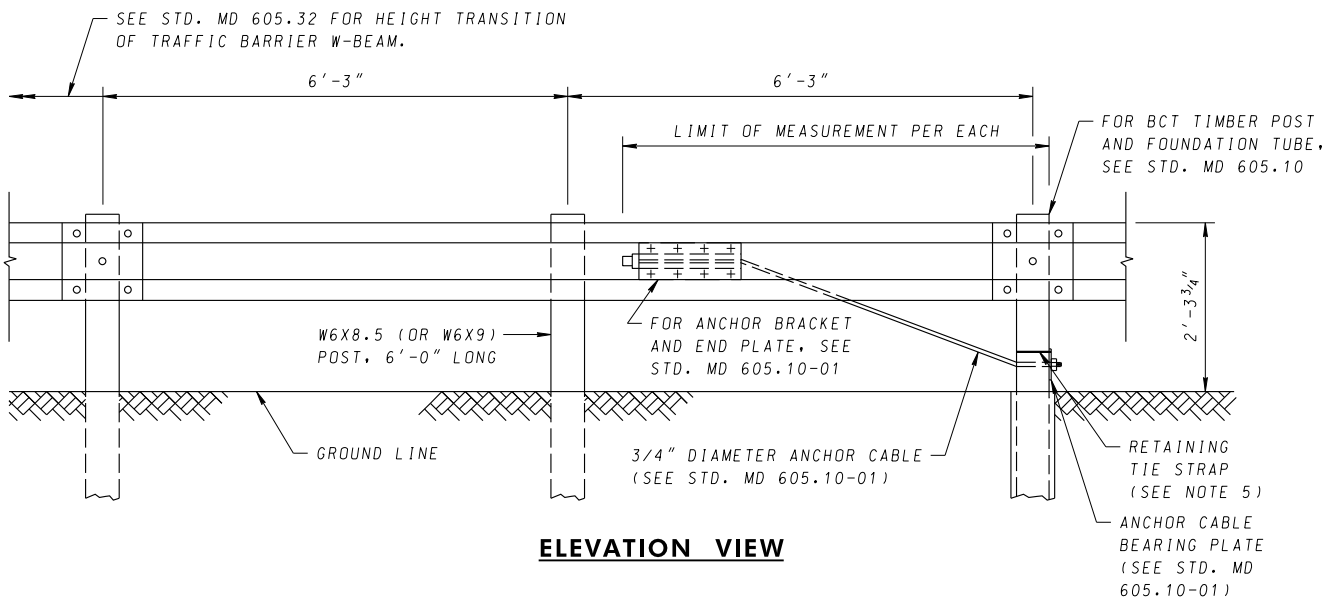

PLAN VIEW



ELEVATION VIEW

NOTES

1. THE USE OF THIS ANCHORAGE IS LIMITED TO ROADWAYS WITH POSTED SPEEDS OF 40 MPH OR LESS AND AADT LESS THAN 10,000.
2. ALL ITEMS (ANCHOR PLATE, CABLE, ROD, DRILLED HOLES, NUTS, BOLTS, ETC) NECESSARY FOR THE ANCHOR SHALL BE MEASURED AND PAID PER EACH OF "TRAFFIC BARRIER W-BEAM RADIUS ANCHORAGE TYPE L." ROUNDED W-BEAM END SECTION (605.10) SHALL BE INCIDENTAL TO THIS PAY ITEM.
3. THE TYPE L ANCHORAGE IS PERMITTED WITHIN A SINGLE RUN OF TRAFFIC BARRIER AS SHOWN. IF A TYPE L ANCHORAGE IS USED, AN ADDITIONAL END TREATMENT IS REQUIRED ON THE DOWNSTREAM END OF THE TRAFFIC BARRIER ONLY IF WITHIN 30' OF OPPOSITE DIRECTION TRAFFIC.
4. THE GROUND STRUT AS SHOWN IN STD. MD 605.10 AND MD 605.10-01 IS NOT REQUIRED IN THE TYPE L ANCHORAGE.
5. PLACE A 3/16" WIDE STAINLESS STEEL RETAINING TIE STRAP AROUND THE SHORT TIMBER BREAKAWAY POST AND ANCHOR CABLE BEARING PLATE. THE STAINLESS STEEL RETAINING TIE STRAP WILL ENSURE THE PROPER ORIENTATION OF THE ANCHOR CABLE BEARING PLATE.

SPECIFICATION 605	CATEGORY CODE ITEMS	 MARYLAND DEPARTMENT OF TRANSPORTATION STATE HIGHWAY ADMINISTRATION STANDARDS FOR HIGHWAYS AND INCIDENTAL STRUCTURES TRAFFIC BARRIER W-BEAM RADIUS ANCHORAGE (TYPE L) STANDARD NO. MD 605.13		
APPROVED	<i>[Signature]</i> DIRECTOR - OFFICE OF HIGHWAY DEVELOPMENT			
APPROVAL REVISIONS	APPROVAL FEDERAL HIGHWAY ADMINISTRATION			
APPROVAL	3-15-06		APPROVAL	4-5-06
REVISED	3-31-20		REVISED	3-30-20
REVISED	3-16-22	REVISED	2-24-22	
REVISED	4-9-25	REVISED	4-3-25	