

BORDER REV. DATE: June 1, 2004

DRILL HOLES

DRILL HOLES

DRILL HOLES



PROPOSED SIGNS

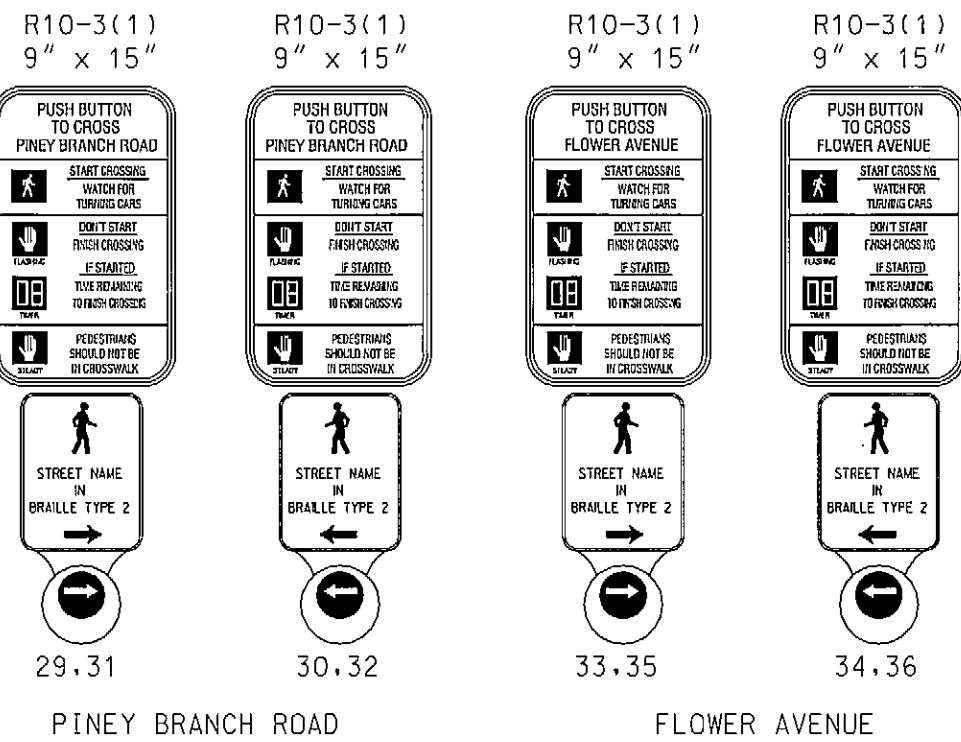
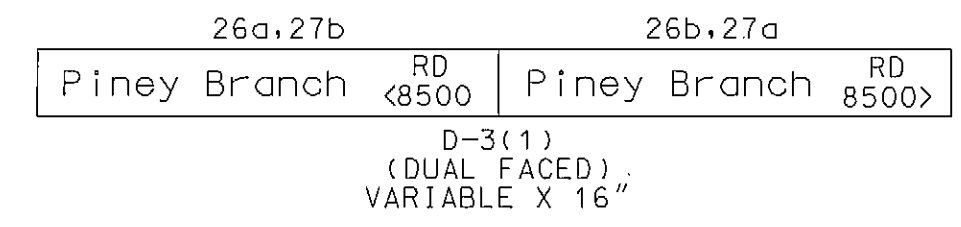
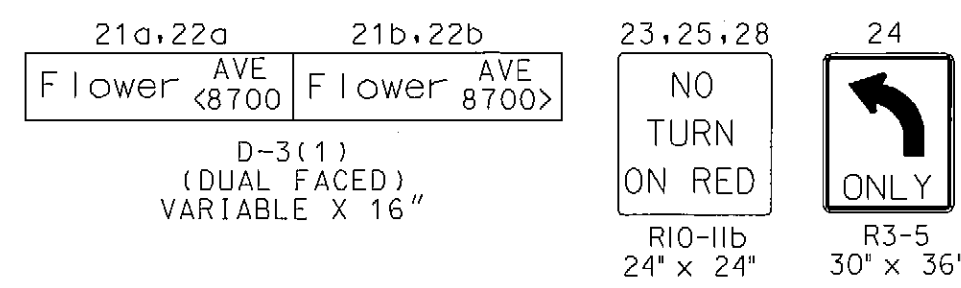

EXISTING SIGNS

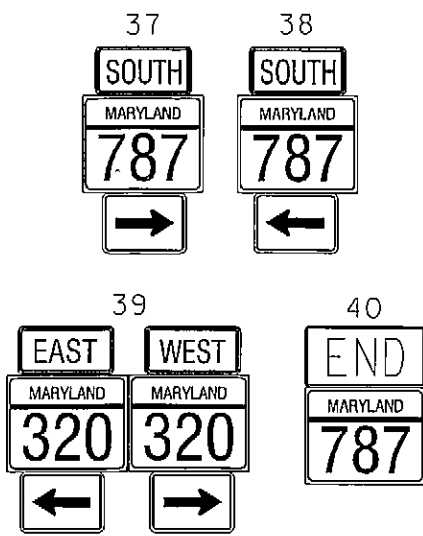

PROPOSED LED SIGNALS

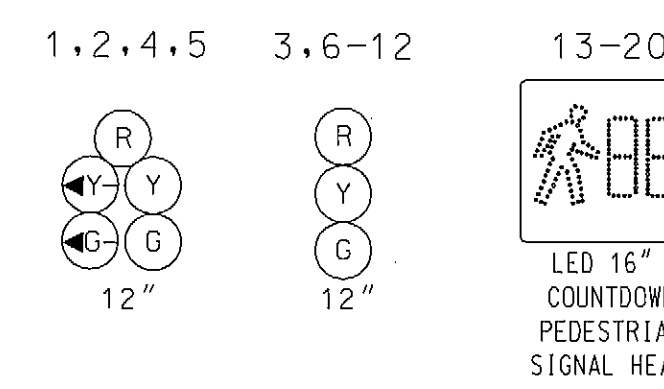

NEMA PHASING

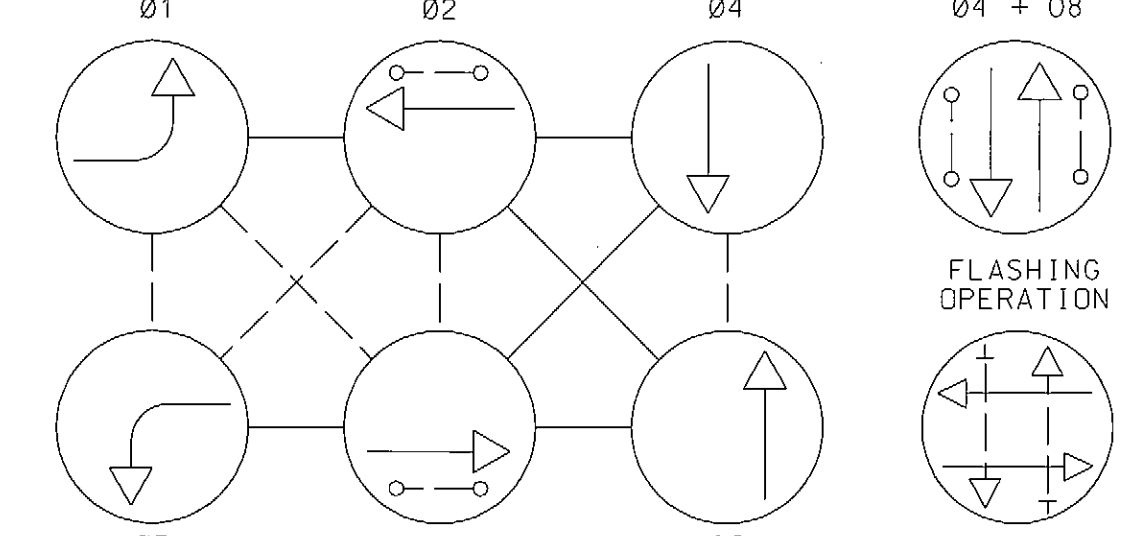

PHASING NOTES:
1. PHASES ASSOCIATED BY A DASHED LINE WILL OPERATE CONCURRENTLY
2. PHASES ASSOCIATED BY A SOLID LINE WILL NOT OPERATE CONCURRENTLY

NOTE: MD 320 IS CONSIDERED TO RUN IN AN EAST/WEST DIRECTION.

CONSTRUCTION DETAILS

- A. Install 27' steel pole with twin 70/50' (cut to 38') mast arms, traffic signal heads, signs, 10' lighting arm with 250 watt HPS luminaire (with photoeye), 20' lighting arm, 3' weatherhead, with 3' riser into Montgomery County splice cabinet, Montgomery County Surveillance Cabinet and Camera arm and will be installed by County forces. Interconnect splice cabinet to be supplied by Montgomery County. (Note: 1-3" and 1-2" 90° polyvinyl chloride (Schedule 80) bend.)
B. Install 27' steel pole (cut to 23') with single 50' mast arm, traffic signal heads, sign, countdown pedestrian signal head and APS pushbutton with pedestrian education sign (R10-3(1)), video detection camera and 3' weatherhead. (Note: 1-3" and 1-2" 90° polyvinyl chloride (Schedule 80) bend.)
C. Install 21' steel pole with single 50' mast arm, traffic signal heads, signs, countdown pedestrian signal head, APS pushbutton with pedestrian education sign (R10-3(1)), 3' weatherhead and video detection camera. (Note: 1-3" and 1-2" 90° polyvinyl chloride (Schedule 80) bend.)
D. Install 10' (18" breakaway coupling foundation STD No. 801.01-01) breakaway pedestal pole with countdown pedestrian signal head and APS pushbutton with pedestrian education sign (R10-3(1)). (Note: 1-3" 90° polyvinyl chloride (Schedule 80) bend.)
E. Install NEMA size "6" base-mounted cabinet and controller with all necessary equipment.
F. Install metered pedestal for underground electrical utility service.
G. Install handhole.
H. Install 4" polyvinyl chloride electrical conduit (Schedule 80) (trenched).
J. Install 3" polyvinyl chloride electrical conduit (Schedule 80) (trenched).
K. Install 2" polyvinyl chloride electrical conduit (Schedule 80) (trenched).
L. Install 12" white heat applied preformed thermoplastic pavement marking. (Crosswalk) (Note: Contractor shall remove all existing crosswalks.)
M. Install 24" white heat applied preformed thermoplastic pavement marking. (Stopline) (Note: Contractor shall remove all existing stopline.)
N. Install proposed parallel handicap ramp (STD. No. MD 655.12) with detectable warning surface (STD. No. MD 655.40).
O. Install proposed perpendicular handicap ramp (STD. No. MD 655.11) with detectable warning surface (STD. No. MD 655.40).
P. Install proposed handicap ramp with detectable warning surface (STD. No. MD 655.40).
Q. Remove existing strain pole and all associated signal equipment as shown. Also the contractor shall contact Mike Kinney at (240)777-8760 to relocate existing pole mounted surveillance camera and cabinet. (Note: Contractor shall remove foundation and backfill 12" below grade.)
R. Remove existing strain pole and all associated signal equipment as shown. (Note: Contractor shall remove foundation 12" below grade and backfill.)
S. Adjust grade of existing handhole as needed.
T. Remove existing cabinet with controller and foundation 12" below grade and backfill.
U. Cap and abandon existing conduit.
V. Use existing handhole.
W. Use existing conduit.
X. Contractor shall remove existing overhead interconnect from existing cabinet at MD 320 and MD 787 east to the existing cabinet at Greenwood Avenue and replace it with proposed 12 pair interconnect. (Note: See Wiring Diagram for details.)
Y. Contractor shall remove existing interconnect from existing span wire and install proposed 12 pair in same span wire, rering if necessary.
Z. Install 4" polyvinyl chloride electrical conduit (Schedule 80) (slotted). To base of utility pole for power service.

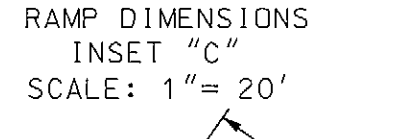
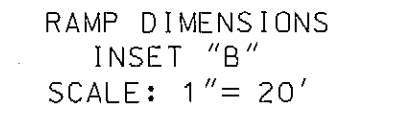
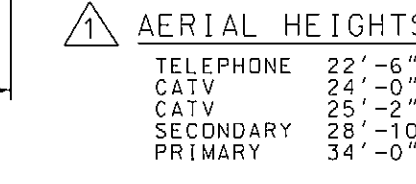
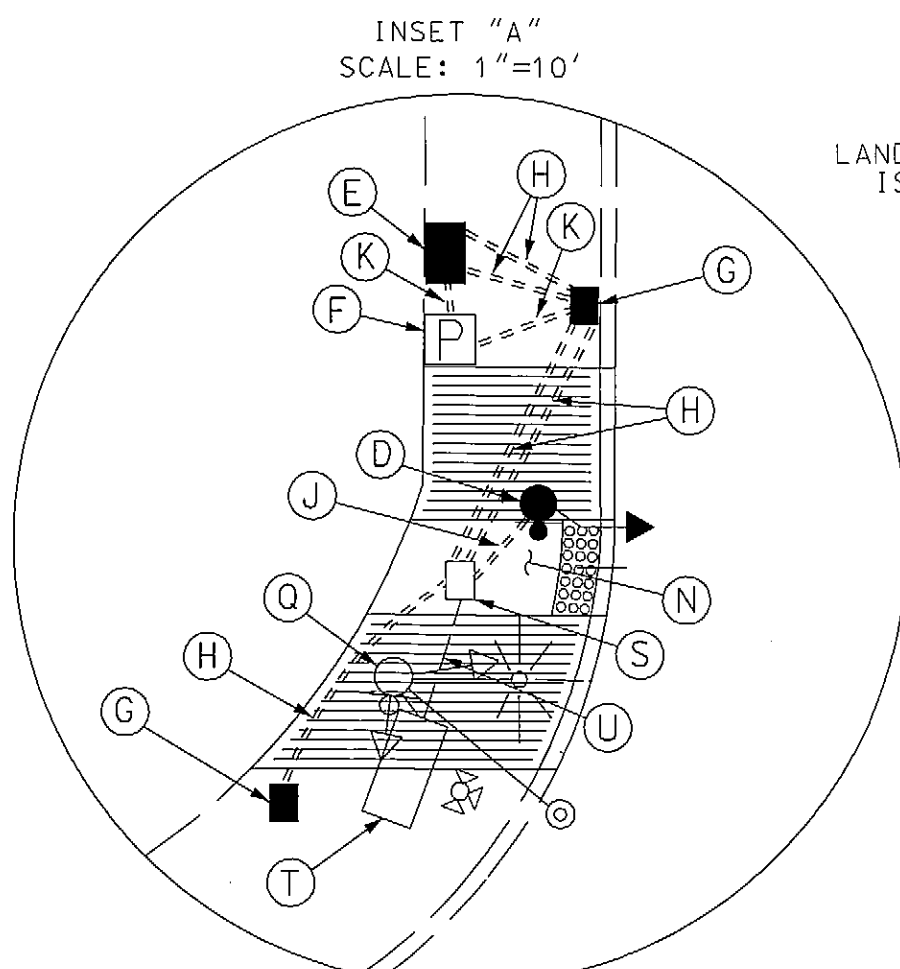
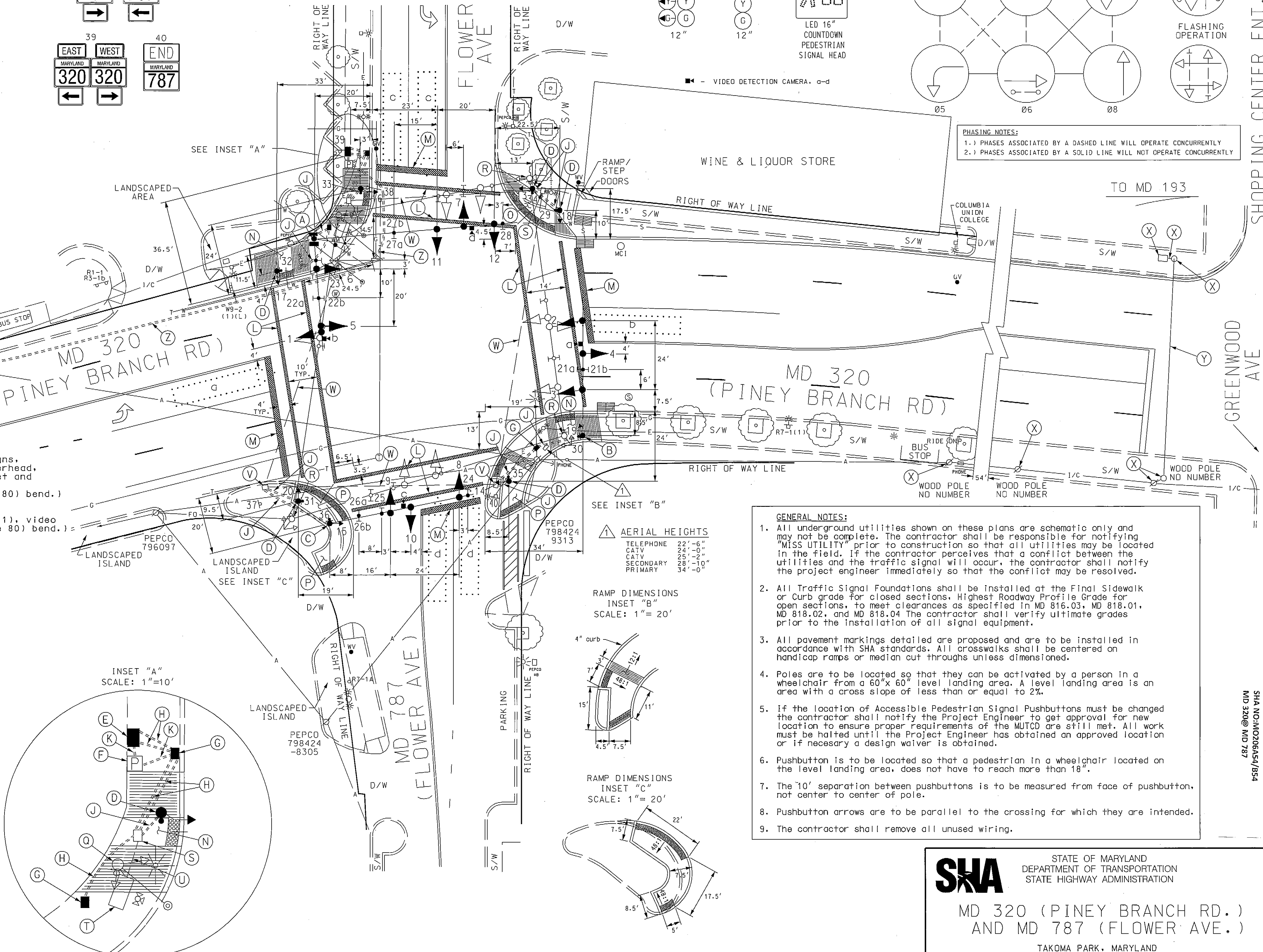

- GENERAL NOTES:
1. All underground utilities shown on these plans are schematic only and may not be complete. The contractor shall be responsible for notifying "MISS UTILITY" prior to construction so that all utilities may be located in the field. If the contractor perceives that a conflict between the utilities and the traffic signal will occur, the contractor shall notify the project engineer immediately so that the conflict may be resolved.
2. All Traffic Signal Foundations shall be installed at the Final Sidewalk or Curb grade for closed sections. Highest Roadway Profile grade for open sections, to meet clearances as specified in MD 816.03, MD 818.01, MD 818.02, and MD 818.04 The contractor shall verify ultimate grades prior to the installation of all signal equipment.
3. All pavement markings detailed are proposed and are to be installed in accordance with SHA standards. All crosswalks shall be centered on handicap ramps or median cut throughs unless dimensioned.
4. Poles are to be located so that they can be activated by a person in a wheelchair from a 60"x 60" level landing area. A level landing area is an area with a cross slope of less than or equal to 2%.
5. If the location of Accessible Pedestrian Signal Pushbuttons must be changed the contractor shall notify the Project Engineer to get approval for new location to ensure proper requirements of the MUTCD are still met. All work must be halted until the Project Engineer has obtained an approved location or if necessary a design waiver is obtained.
6. Pushbutton is to be located so that a pedestrian in a wheelchair located on the level landing area, does not have to reach more than 18".
7. The 10' separation between pushbuttons is to be measured from face of pushbutton, not center to center of pole.
8. Pushbutton arrows are to be parallel to the crossing for which they are intended.
9. The contractor shall remove all unused wiring.

STATE OF MARYLAND DEPARTMENT OF TRANSPORTATION STATE HIGHWAY ADMINISTRATION
MD 320 (PINEY BRANCH RD.) AND MD 787 (FLOWER AVE.)
TAKOMA PARK, MARYLAND
TRAFFIC SIGNAL PLAN
SCALE 1" = 20' DATE 7/99 CONTRACT NO.

GEOMETRIC LEGEND table with columns for PROPOSED and EXISTING, and rows for AERIAL CABLE, ELECTRIC, TELEPHONE, GAS, SEWER, WATER, CABLE TV.

REVISION "A" logo for STREET TRAFFIC STUDIES, LTD. with address 400 Crain Hwy, W. Glen Burnie, MD 21061 and phone numbers.

APPROVALS table with columns for TEAM LEADER, ASST. DIV. CHIEF, DIVISION CHIEF, OFFICE DIRECTOR, and a diagonal 'ORIGINAL ON FILE' stamp.

REVISIONS table with columns for description, date, and initials.

DESIGNED BY, DRAWN BY, CHECKED BY, F.A.P. NO., TS NO., DRAWING NO., SHEET NO., and CONTRACT NO. fields.

PLOTTED: THURSDAY, JANUARY 07, 2010 AT 8:18:18 AM FILE: 5675REVHCR.DGN

TOD NO: 345-21 SHA NO: 040805A/954 MD 320@ MD 787