

24" x 24" SIGN BLANK
0.063" MIN THICKNESS

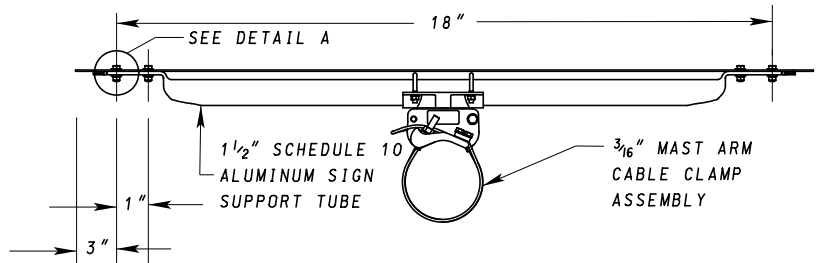
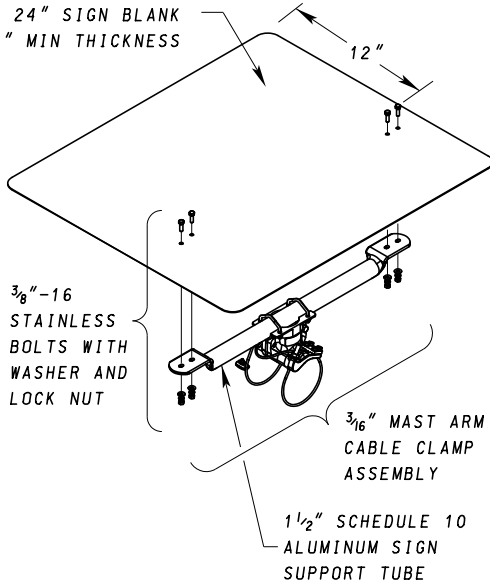

3/8"-16 X 1 1/4" 304 S.S. BOLT
304 S.S. FLATWASHER
24"X24" SIGN BLANK

SIGN BRACKET
304 S.S. FLATWASHER
NYLON LOCK NUT

DETAIL A - HARDWARE

MAST ARM VIBRATION MITIGATION DEVICE DETAIL - OPTION A

24" x 24" SIGN BLANK
0.063" MIN THICKNESS

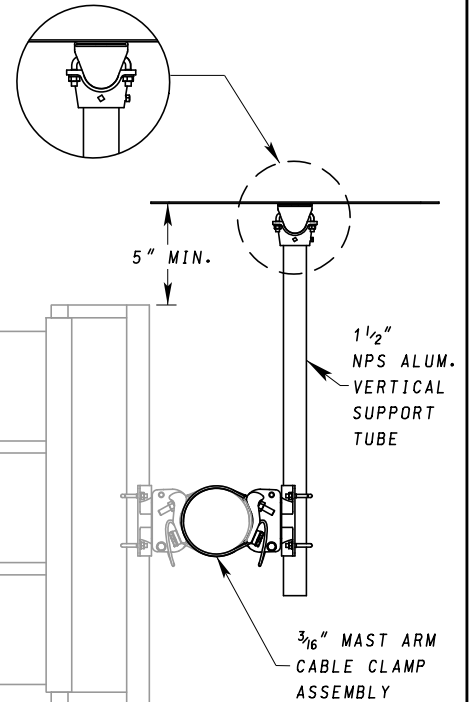
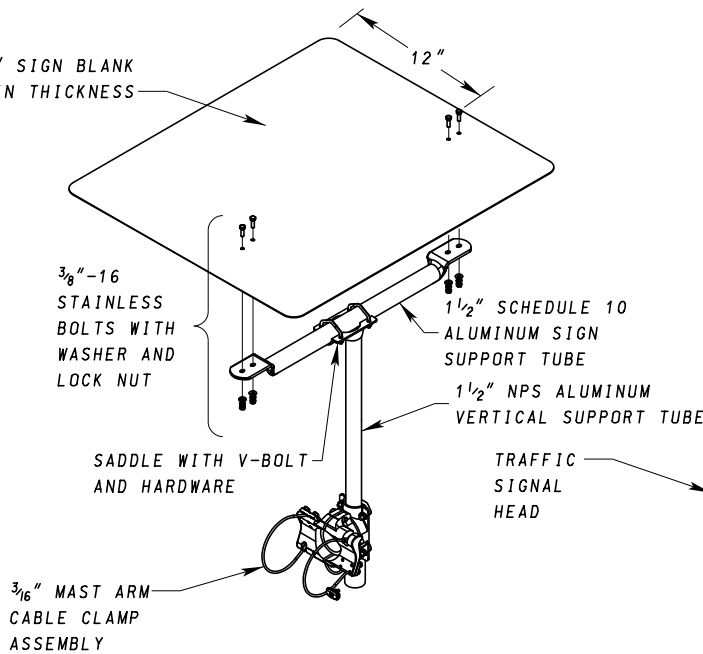

MAST ARM VIBRATION MITIGATION DEVICE DETAIL - OPTION B

NOTES:

1. INSTALL VIBRATION MITIGATION DEVICE WITHIN 5 FT. OF MAST ARM TIP.
2. MITIGATION DEVICE SHALL BE INSTALLED ON ALL 75 FT. MAST ARMS.
3. MITIGATION DEVICE FOR ALL OTHER MAST ARMS SHALL BE INSTALLED IF EXCESSIVE GALLOPING IS OBSERVED.

SPECIFICATION 818	CATEGORY CODE ITEMS
APPROVED	<i>Cedric Wald</i> DIRECTOR - OFFICE OF TRAFFIC AND SAFETY
APPROVAL SHA REVISIONS	APPROVAL FEDERAL HIGHWAY ADMINISTRATION
APPROVAL 11-20-19	APPROVAL 9-4-19
REVISED	REVISED
REVISED	REVISED
REVISED	REVISED

MOT MARYLAND DEPARTMENT OF TRANSPORTATION
STATE HIGHWAY ADMINISTRATION

STANDARDS FOR HIGHWAYS AND INCIDENTAL STRUCTURES

**MAST ARM VIBRATION
MITIGATION DEVICE**

STANDARD NO.

MD 818.02-01