

14" DIA. HOLE FOR 4"x 4" & 4"x 6"
 18" DIA. HOLE FOR 6"x 6" & 6"x 8"

NOTE:

TREATED WOODEN POST SHALL BE PLACED IN PRE-DUG HOLE IN GROUND, BACKFILLED USING SUITABLE MATERIAL, AND TAMPED THOROUGHLY TO PROVIDE A RIGID SUB-SURFACE CONDITION AROUND THE POST.

TYPICAL FOUNDATION FOR WOOD SUPPORTS

WOOD POST MODIFICATIONS FOR BREAKAWAY FEATURE

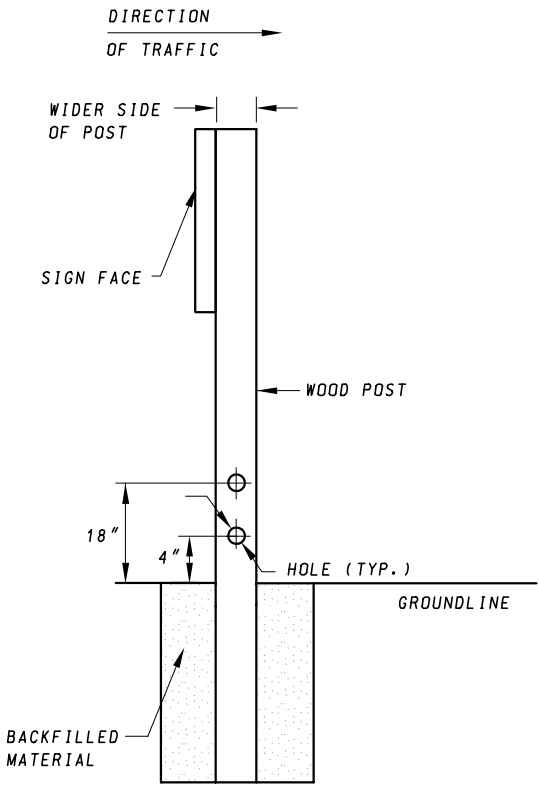



POST SIZE	HOLE DIA. (IN.)
4" x 4"	--
4" x 6"	1 1/2
6" x 6"	2
6" x 8"	3

NOTES:

1. ALL WOOD POSTS LARGER THAN 4"x 4" SHALL BE MADE BREAKAWAY BY DRILLING TWO HOLES CENTERED AT 4" AND 18" ABOVE THE GROUNDLINE AND PERPENDICULAR TO THE ROADWAY.
2. ALL SUPPORTS WITHIN THE CLEAR ZONE SHALL BE BREAKAWAY UNLESS PROTECTED.

WOOD POST MODIFICATIONS FOR BREAKAWAY FEATURE

SPECIFICATION 812	CATEGORY CODE ITEMS
APPROVED	 DIRECTOR - OFFICE OF TRAFFIC AND SAFETY
	APPROVAL • SHA REVISIONS
	APPROVAL 10-10-00
	REVISED 5-17-07
	REVISED
APPROVAL • FEDERAL HIGHWAY ADMINISTRATION	
APPROVAL 2-1-01	
REVISED 5-2-07	
REVISED	
REVISED	

Maryland Department of Transportation
STATE HIGHWAY ADMINISTRATION
 STANDARDS FOR HIGHWAYS AND INCIDENTAL STRUCTURES

WOOD SIGN SUPPORT FOUNDATIONS AND BREAKAWAY FEATURES

STANDARD NO. MD 812.01