

RECESSED DIRECT SRPM & LENS - WITHOUT HOLDER - ONE WAY

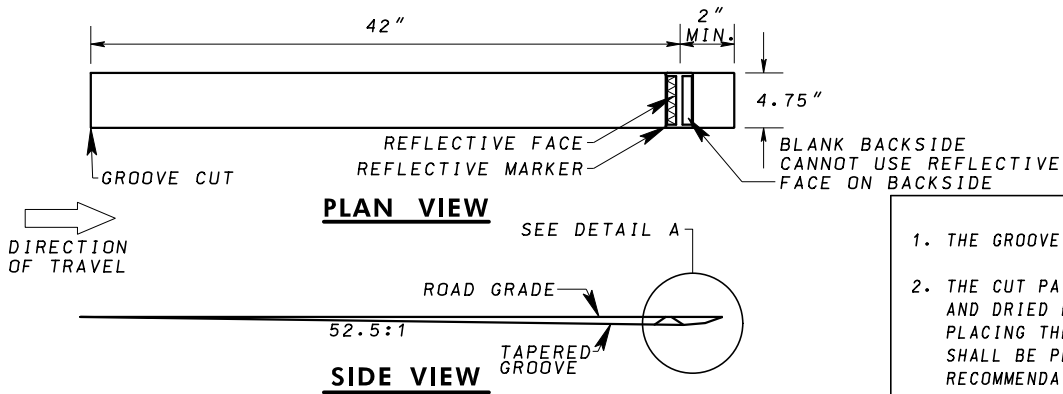

NOTES:

1. THE GROOVE SHALL BE CUT AS SHOWN.
2. THE CUT PATTERN SHALL BE CLEANED, AND DRIED BY COMPRESSED AIR BEFORE PLACING THE ADHESIVE. THE ADHESIVE SHALL BE PLACED PER THE MANUFACTURERS RECOMMENDATIONS.
3. EPOXY ADHESIVE SHALL BE INSTALLED DURING WEATHER CONDITIONS CONSISTENT WITH MANUFACTURERS RECOMMENDATIONS.
4. REFLECTIVE MARKER SHALL BE INSTALLED PER MANUFACTURERS RECOMMENDATIONS AND SHALL BE SELECTED FROM THE QUALIFIED PRODUCTS LIST (QPL).
5. THE MARKER SHALL BE PROTECTED FROM TRAFFIC UNTIL THE ADHESIVE HAS PROPERLY HARDENED.
6. REFLECTIVE FACE COLORS SHALL BE DETERMINED BASED ON THE APPLICATION.
7. RECESSED DIRECT SRPM SHALL NOT BE USED ON CONCRETE BRIDGE DECKS.
8. RECESSED DIRECT SRPM PLACEMENT SHALL AVOID LOOP DETECTORS AND LOOP DETECTOR LEAD-INS.
9. NEW ASPHALT PAVEMENT SHALL BE ALLOWED TO PROPERLY SETUP, CURE AND COOL BEFORE INSTALLATION OF GROOVES TO AVOID DAMAGE TO THE PAVEMENT SURFACE.

RECESSED DIRECT SRPM & LENS - WITHOUT HOLDER - TWO WAY

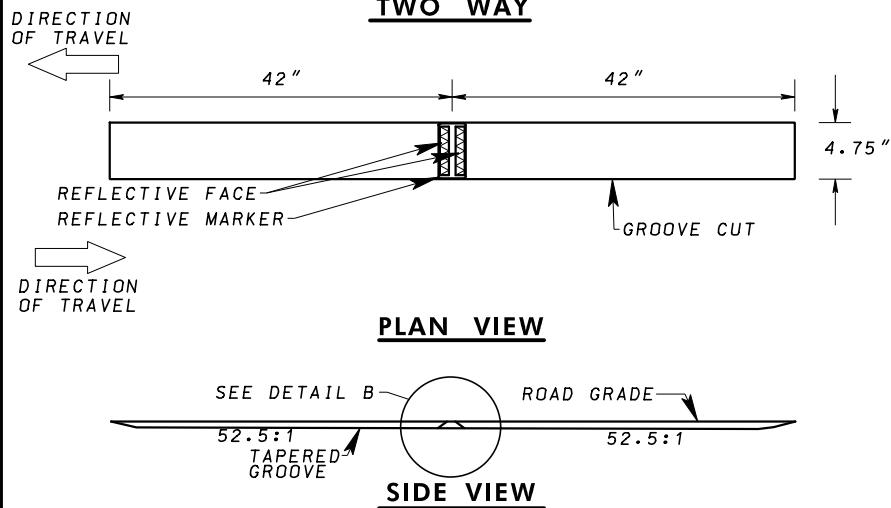

RECESSED DIRECT SRPM REFLECTIVE MARKER WITHOUT HOLDER

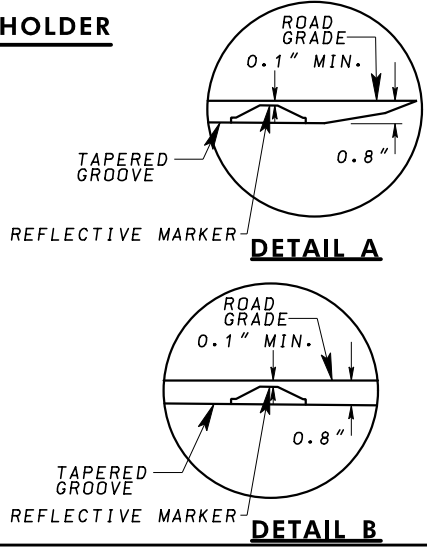
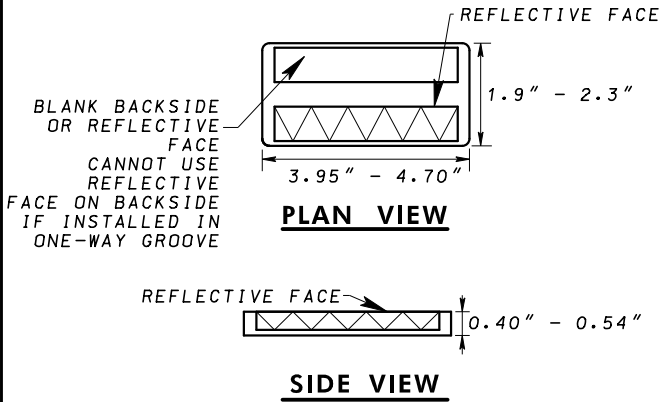

SPECIFICATION 557	CATEGORY CODE ITEMS
APPROVED <i>Cedric Wald</i> DIRECTOR - OFFICE OF TRAFFIC AND SAFETY	
APPROVAL SHA REVISIONS	APPROVAL FEDERAL HIGHWAY ADMINISTRATION
APPROVAL 1-30-25	APPROVAL 1-24-25
REVISED	REVISED
REVISED	REVISED
REVISED	REVISED

MDT MARYLAND DEPARTMENT OF TRANSPORTATION
STATE HIGHWAY ADMINISTRATION

**STANDARDS FOR HIGHWAYS AND INCIDENTAL STRUCTURES
RECESSED DIRECT SNOWPLOWABLE RAISED
PAVEMENT MARKER WITHOUT HOLDER
AND LENS**

STANDARD NO. MD 557.02