

ALIGN FACE OF W BEAM WITH FLOW LINE

TYPE B OR C COMBINATION CURB AND GUTTER OR TYPE B OR C CURB.

* SEE NOTE 5

PLACEMENT AT CURBS (WITHOUT SIDEWALKS)

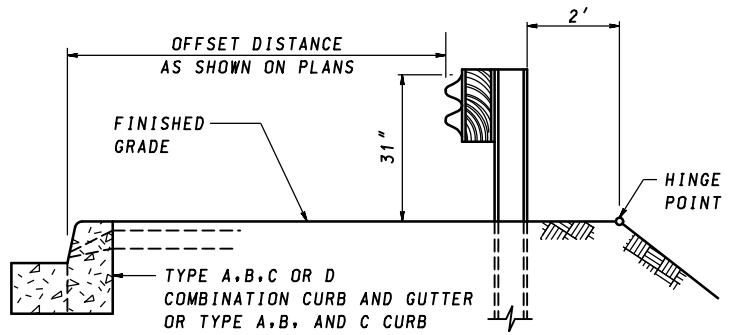

PLACEMENT BEHIND SIDEWALK AREA

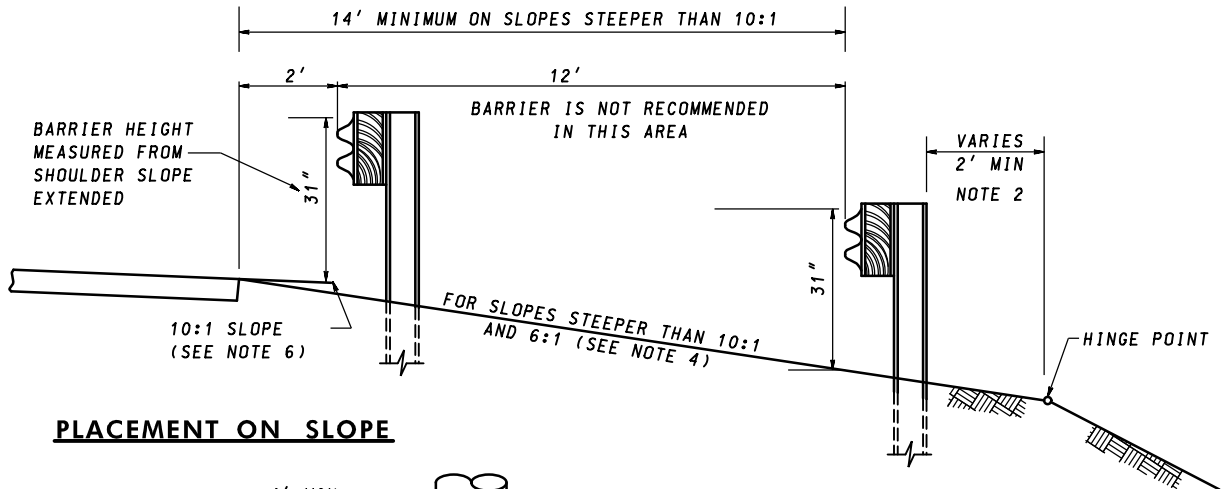

PLACEMENT ON SLOPE

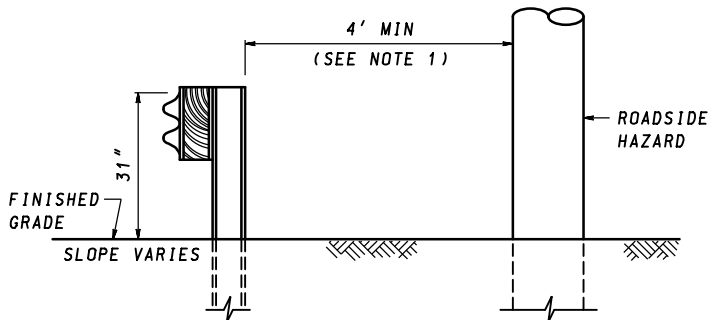

MINIMUM OFFSET TO HAZARD

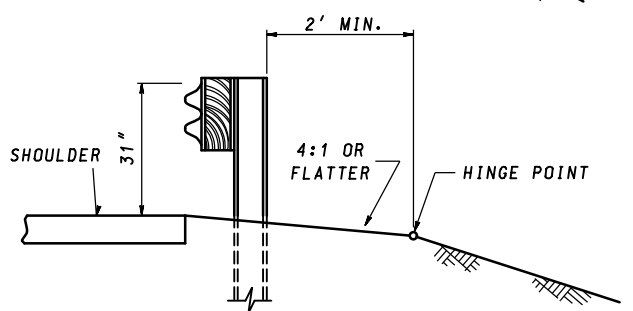

PLACEMENT AT SHOULDER

NOTES

1. THE MINIMUM DIMENSION SHOWN CAN BE REDUCED BY STIFFENING THE TRAFFIC BARRIER SYSTEM.
2. 8'-0" LONG POSTS ARE TO BE USED WHEN THE DISTANCE FROM THE BACK OF THE W BEAM POST TO THE HINGE POINT IS LESS THAN 2' AND THE SLOPE BEYOND THE HINGE IS STEEPER THAN 4:1.
3. WHEN THE FACE OF THE TRAFFIC BARRIER IS MORE THAN 2' FROM THE SHOULDER EDGE THE HEIGHT MEASURED FROM THE EXISTING GROUND SHALL BE 31".
4. WHEN SLOPE IS STEEPER THAN 6:1, THE FACE OF THE BARRIER MUST BE ALIGNED WITH THE EDGE OF SHOULDER.
5. STIFFEN THE TRAFFIC BARRIER W BEAM WHEN TYPE 'B' COMBINATION CURB/GUTTER OR TYPE 'B' CURB IS USED AT POSTED SPEEDS 45 MPH OR GREATER.
6. SLOPE IN FRONT OF BARRIER INSTALLED 2' OFFSET FROM SHOULDER EDGE MUST BE 10:1 OR SHALLOWER.
7. HEIGHT OF TRAFFIC BARRIER IS MEASURED TO THE TOP OF THE W-BEAM.

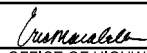
SPECIFICATION 605	CATEGORY CODE ITEMS
APPROVED	 DIRECTOR - OFFICE OF HIGHWAY DEVELOPMENT
APPROVAL REVISIONS	APPROVAL FEDERAL HIGHWAY ADMINISTRATION
APPROVAL	6-4-84
REVISD	4-5-13
REVISD	12-21-17
REVISD	6-22-18
APPROVAL	8-1-94
REVISD	11-17-10
REVISD	12-20-17
REVISD	4-30-18

MDOT MARYLAND DEPARTMENT OF TRANSPORTATION
STATE HIGHWAY ADMINISTRATION

STANDARDS FOR HIGHWAYS AND INCIDENTAL STRUCTURES

**TRAFFIC BARRIER W BEAM
PLACEMENT DETAILS**

STANDARD NO.

MD 605.31