

**ONE-WAY THREE OR FOUR - SECTION
12" SIGNAL HEADS
THREE - SECTION 12"/8" COMBINATIONS**

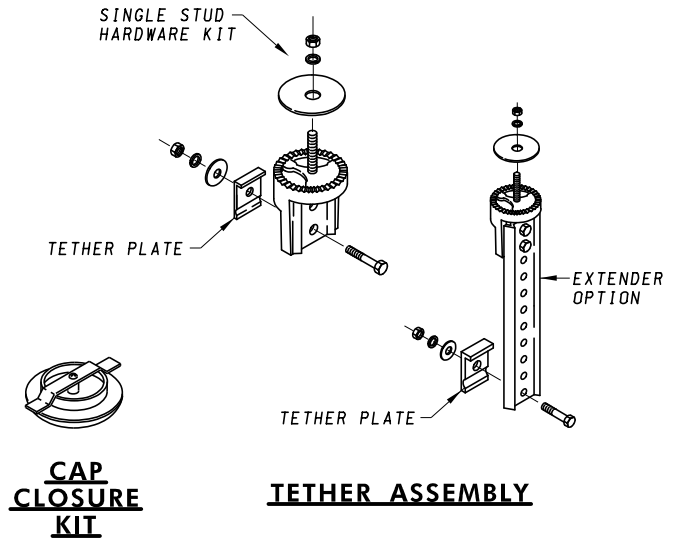

**CAP
CLOSURE
KIT**

TETHER ASSEMBLY

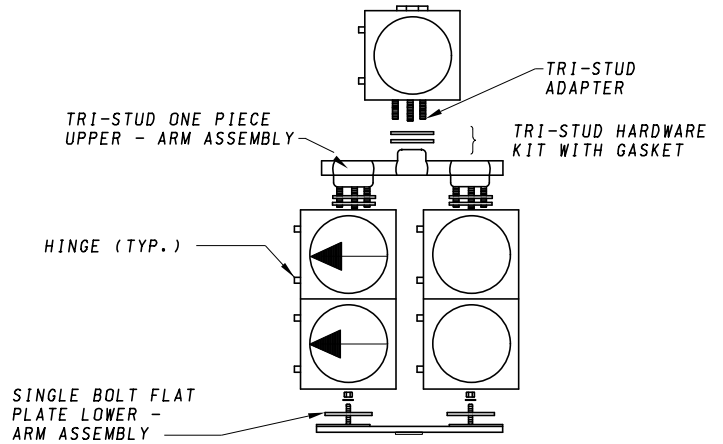

**ONE-WAY, FIVE-SECTION
12" SIGNAL HEADS**

NOTES:

1. ALL CAST MOUNTING HARDWARE SHALL BE ALODINE FINISHED ALUMINUM.
2. ALL BOLTS SHALL BE STAINLESS STEEL.

MATERIALS

TYPE OF INDICATION	RIGID MOUNTED	SPAN WIRE MOUNTED
THREE SECTION 8"/12" COMBINATION	POLYCARBONATE	POLYCARBONATE
PEDESTRIAN SIGNAL INDICATION	ALUMINUM	N/A
FIVE SECTION 12" SIGNAL HEAD	POLYCARBONATE	TOP SIGNAL INDICATION SHALL BE ALUMINUM, BOTTOM 4 SECTION SHALL BE POLYCARBONATE
OPTICALLY PROGRAMMED SIGNAL HEAD INDICATION	N/A	N/A
ONE, TWO, THREE, OR FOUR SECTION 12" SIGNAL HEAD	POLYCARBONATE	POLYCARBONATE

SPECIFICATION 814	CATEGORY CODE ITEMS
APPROVED	<i>Cedric Wall</i> DIRECTOR - OFFICE OF TRAFFIC AND SAFETY
APPROVAL SHA REVISIONS	APPROVAL FEDERAL HIGHWAY ADMINISTRATION
APPROVAL 7-1-94	APPROVAL 7-1-94
REVISED 5-17-07	REVISED 5-2-07
REVISED 4-16-19	REVISED 3-25-19
REVISED	REVISED

MDT MARYLAND DEPARTMENT OF TRANSPORTATION
STATE HIGHWAY ADMINISTRATION

STANDARDS FOR HIGHWAYS AND INCIDENTAL STRUCTURES

SIGNAL HEAD MOUNTING DETAILS

STANDARD NO.

MD 814.02