

TWO (2) POUNDS-PER-FOOT STEEL U-CHANNELS ATTACHED WITH  $\frac{5}{16}$ " HEX BOLTS, TWO WASHERS AND NUT (USE IF REQUIRED)

**NOTES:**

1. ROUTE MARKER ASSEMBLIES THAT REQUIRE SUPPORTS LARGER THAN TWO 4" x 4" OR TWO 4" x 6" DRILLED WOOD POSTS AND THAT ARE NOT PROTECTED BY PHYSICAL TRAFFIC BARRIERS SHALL BE INSTALLED ON BREAKAWAY TYPE STEEL SUPPORTS.
2. REFER TO WOOD SIGN SUPPORTS POSTS SIZES & SPACING STANDARD PLATE FOR DETAILS.

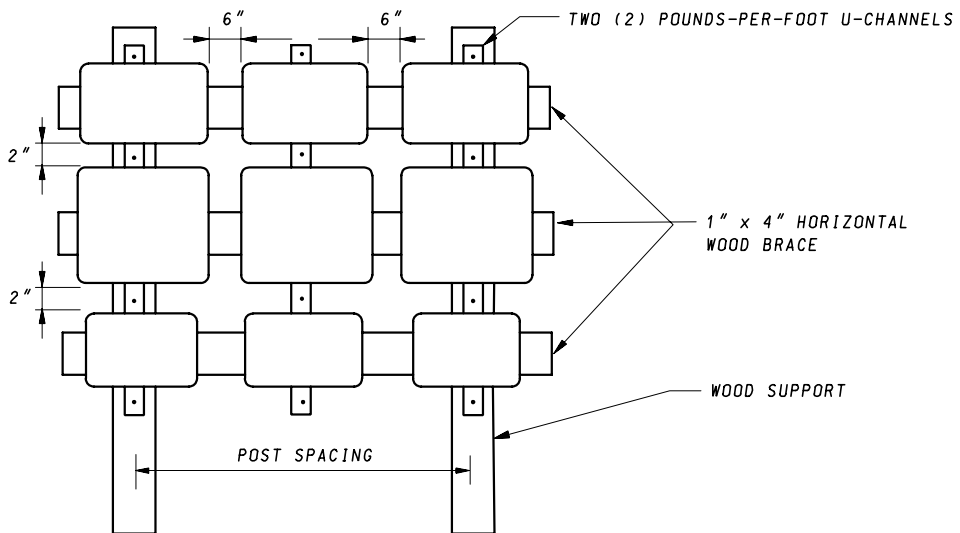

**TYPICAL ROUTE MARKER ASSEMBLY INSTALLATION (48" x 36" SHIELD)**

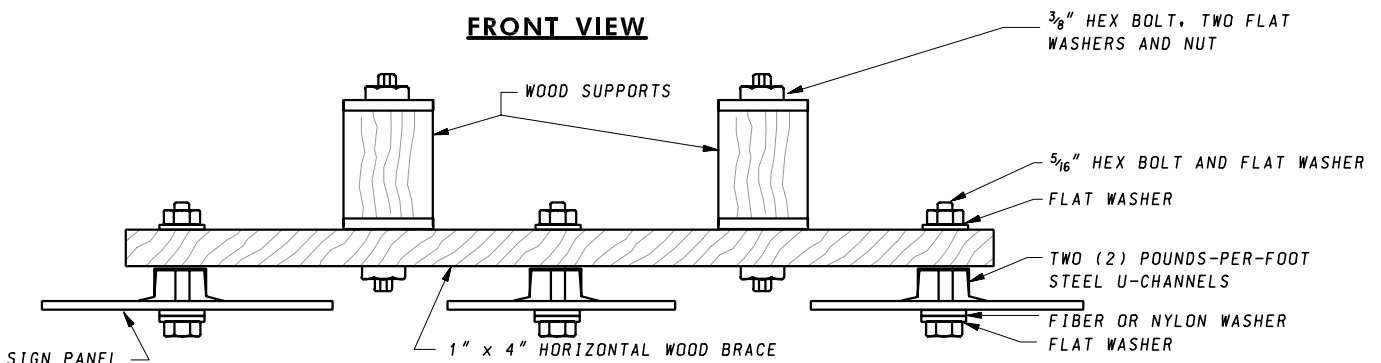

**FRONT VIEW**



**MULTI ROUTE MARKER INSTALLATION**

SPECIFICATION <b>812, 813</b>	CATEGORY CODE ITEMS
APPROVED	 DIRECTOR - OFFICE OF TRAFFIC AND SAFETY
	APPROVAL • SHA REVISIONS
	APPROVAL 2-21-95
	REVISED 5-17-07
	REVISED
	REVISED
APPROVAL • FEDERAL HIGHWAY ADMINISTRATION	
APPROVAL 2-21-95	
REVISED 5-2-07	
REVISED	
REVISED	

**Maryland Department of Transportation**  
**STATE HIGHWAY ADMINISTRATION**  
 STANDARDS FOR HIGHWAYS AND INCIDENTAL STRUCTURES

**WOOD SIGN SUPPORTS**  
**ROUTE MARKER ASSEMBLIES**

STANDARD NO.

MD 812.03