

**PLAN**

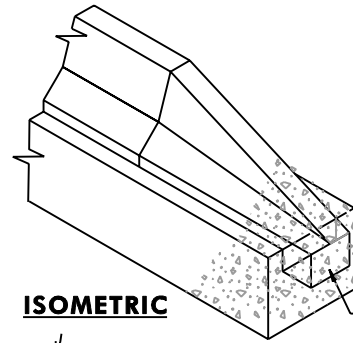

**ISOMETRIC**

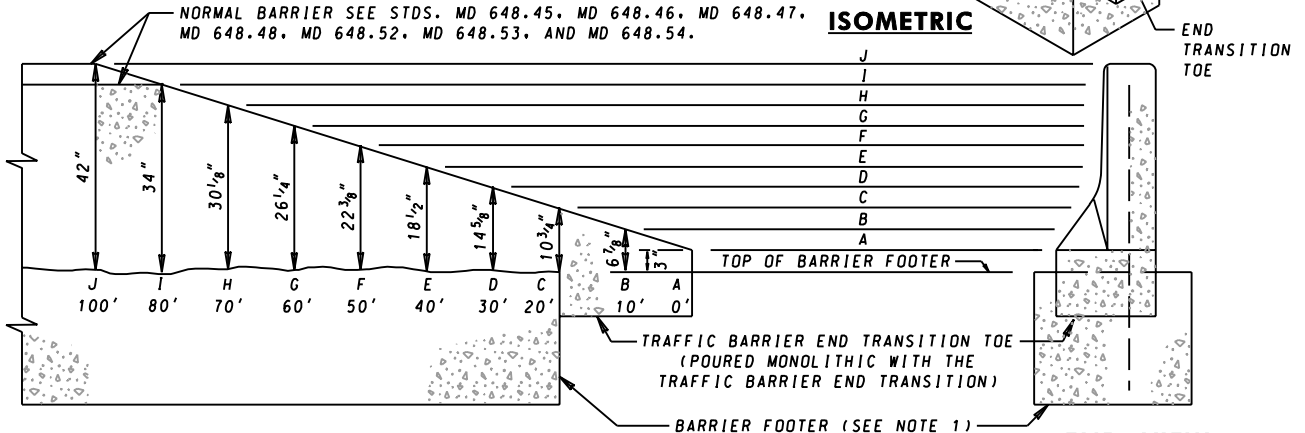

**ELEVATION**

**END VIEW**

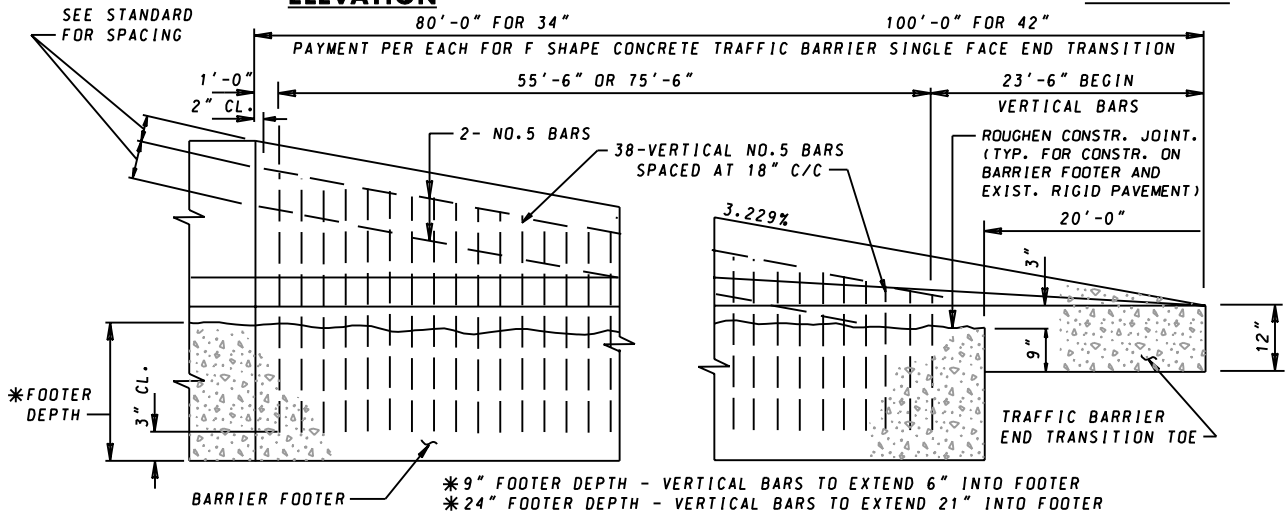

**REINFORCEMENT STEEL DETAIL**

**NOTES**

1. THE TRAFFIC BARRIER END TRANSITION AND BARRIER FOOTER SHALL BE CONSTRUCTED USING THE FIXED FORM METHOD. SEE STDS. MD 648.45, MD 648.46, MD 648.47, MD 648.52, MD 648.53, AND MD 648.54 FOR BARRIER FOOTER DETAILS. THE BARRIER AND FOOTER SHALL BE CAST SEPARATELY. MONOLITHIC PLACEMENT NOT PERMITTED.
2. THE TRAFFIC BARRIER END TRANSITION AND BARRIER FOOTER SHALL BE CONSTRUCTED USING CONCRETE MIX NO.6 (4500 PSI).
3. ALL REINFORCEMENT BARS, INCLUDING ENDS, AND TIES SHALL BE EPOXY COATED. ALL BAR LAPS TO BE 30 BAR DIAMETERS. TIE BARS TOGETHER.
4. THIS TRAFFIC BARRIER END TRANSITION IS PROHIBITED WHEN THE DESIGN SPEED IS 45 MPH OR GREATER. THE ENGINEER MUST DETERMINE THE TYPE OF END TREATMENT REQUIRED FOR DESIGN SPEEDS OVER 45 MPH.
5. THE COST OF THE BARRIER END TRANSITION TOE, REINFORCEMENT, DRILLED HOLES, GROUT, LABOR, TOOLS, EQUIPMENT, ETC., SHALL BE INCIDENTAL TO THE CONTRACT UNIT PRICE PER EACH FOR THE 34 INCH OR 42 INCH F SHAPE CONCRETE TRAFFIC BARRIER SINGLE FACE END TRANSITION.
6. TOLERANCES IN DIMENSIONS SHOWN SHALL BE WITHIN 1/4".

SPECIFICATION <b>604</b>	CATEGORY CODE ITEMS
APPROVED <i>Kirk G. McCall</i> DIRECTOR - OFFICE OF HIGHWAY DEVELOPMENT	
	APPROVAL • SHA REVISIONS
	APPROVAL • FEDERAL HIGHWAY ADMINISTRATION
	APPROVAL <b>3-1-01</b>
	APPROVAL <b>3-28-01</b>
REVISED <b>10-1-01</b>	REVISED
REVISED	REVISED
REVISED	REVISED

**Maryland Department of Transportation**  
**STATE HIGHWAY ADMINISTRATION**  
 STANDARDS FOR HIGHWAYS AND INCIDENTAL STRUCTURES  
**34 INCH AND 42 INCH F SHAPE**  
**CONCRETE TRAFFIC BARRIER**  
**SINGLE FACE END TRANSITION**  
**STANARD NO. MD 648.51**