

PLAN

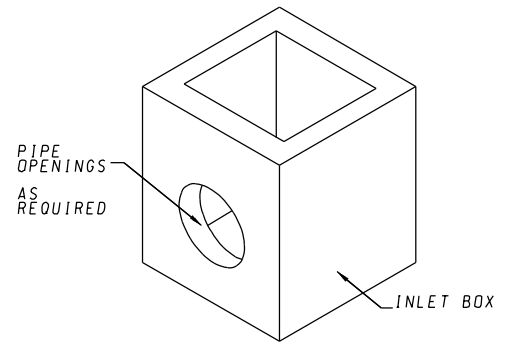

ISOMETRIC VIEW

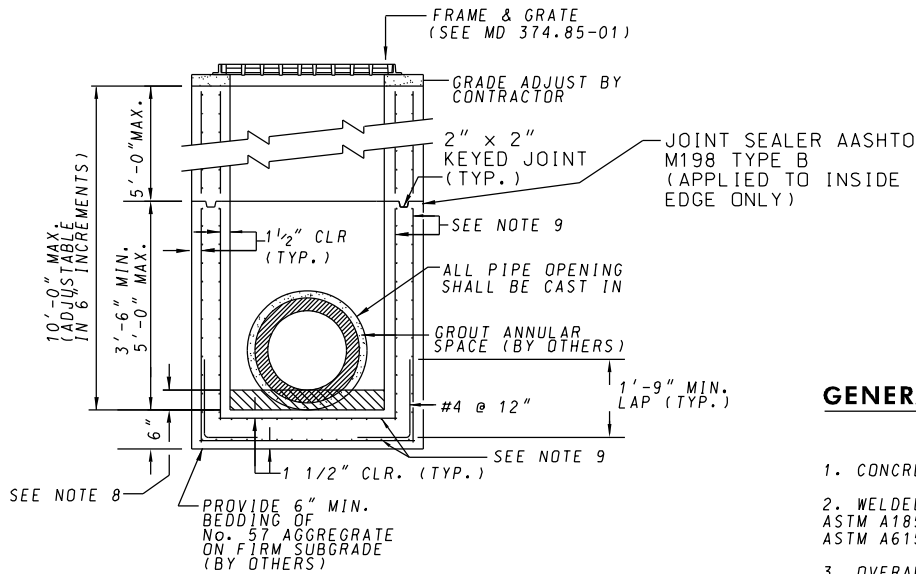

SECTION A-A

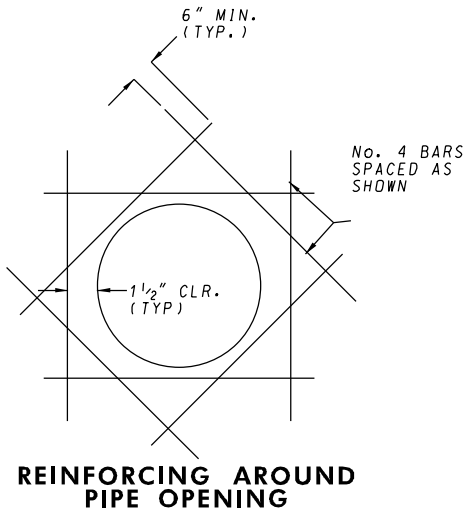

REINFORCING AROUND PIPE OPENING

GENERAL NOTES:

1. CONCRETE SHALL BE MIX No. 6.
2. WELDED WIRE FABRIC SHALL CONFORMS TO ASTM A185. DEFORMED STEEL CONFORMS TO ASTM A615 GRADE 60.
3. OVERALL HEIGHT OF PRECAST IS ADJUSTABLE IN 6" INCREMENTS. FINAL GRADE ADJUSTMENT SHALL BE MADE BY CONTRACTOR WITH CONCRETE MIX No. 6.
4. THREADED PLASTIC INSERTS TO BE PROVIDED FOR HANDLING.
5. LADDER RUNGS SHALL BE IN ACCORDANCE WITH STD. MD 383.91 AND STD. MD 383.92 OR AS DIRECTED BY THE ENGINEER.
6. PLACEMENT OF SUBGRADE DRAINAGE WILL BE AS DIRECTED BY THE ENGINEER OR AS NEEDED ON THE CONSTRUCTION PLANS.
7. MINIMUM DEPTH PAYMENT PER "EACH" INLETS INCLUDES DEPTH UP TO 3'-6". VERTICAL DEPTH PAYMENT PER LINEAR FOOT FOR DEPTHS IN EXCESS OF 3'-6".
8. CONCRETE OR BRICK INVERT TO BE PROVIDED IN THE FIELD AND SHALL SLOPE 2" PER FOOT TOWARDS THE OUTLET OR AS DIRECTED.
9. REINFORCING: WALLS - 2 LAYERS OF 4X4 W4.0 X W4.0 WELDED WIRE FABRIC; BASE - 2 LAYERS OF 4X4 W5.0 X W5.0 WELDED WIRE FABRIC WITH 1/2" COVER (TYP.).
10. FROM CURB LINE, INLET HAS BEEN DESIGNED FOR HS-25 LOADING, ACCORDING TO AASHTO LRFD BRIDGE DESIGN SPECIFICATIONS.

SPECIFICATION	CATEGORY CODE ITEMS
APPROVED	DIRECTOR - OFFICE OF HIGHWAY DEVELOPMENT
	APPROVAL • SHA REVISIONS
	APPROVAL 7-14-08
	REVISD 10-7-14
	REVISD
	REVISD

Maryland Department of Transportation
STATE HIGHWAY ADMINISTRATION
 STANDARDS FOR HIGHWAYS AND INCIDENTAL STRUCTURES

STANDARD ADA COMPLIANT INLET
SINGLE GRATE

STANDARD NO. MD 374.85