

**PRECAST CONCRETE TROUGH SLAB**  
(6" THICK)

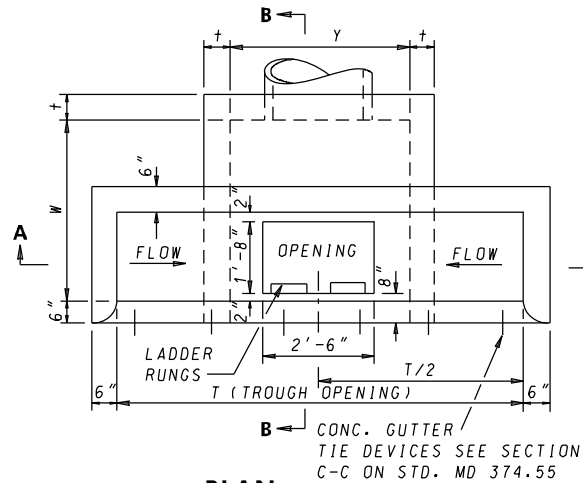

**PLAN**  
(SHOWN WITHOUT TROUGH SLAB)

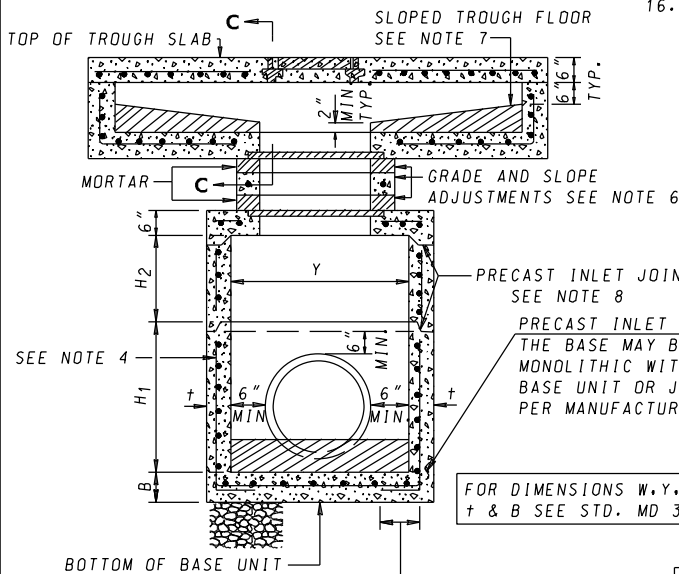

LAP SPLICE REINFORCEMENT 1'-0" (TYP.) AROUND OUTSIDE CORNERS AS SHOWN. (MONOLITHIC BASE ONLY)

**SECTION A-A**  
(SHOWN AS PRECAST)

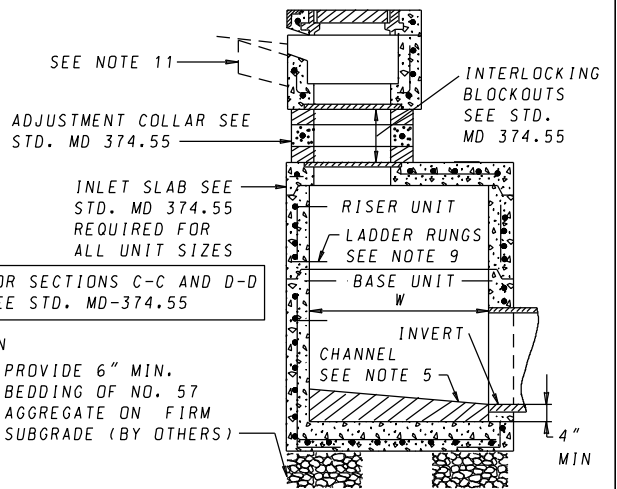

**SECTION B-B**  
(SHOWN AS PRECAST)

**NOTES**

1. THIS STANDARD TO BE USED WITH TYPE A COMBINATION CURB AND GUTTER ONLY.
2. CURB OPENINGS SHALL NOT ENCRDACH ON CROSSWALK AREAS.
3. CONCRETE SHALL BE MIX NO.6 (4500 PSI) FOR PRECAST UNITS AND CONCRETE MIX NO.3 (3500 PSI) FOR CAST IN PLACE UNITS.
4. INLET MAY BE PRECAST OR CAST IN PLACE. ON WALLS, REINFORCEMENT SHALL BE AS SHOWN ON TABLE (STD MD 379.61.01) WITH 2" COVER FOR WELDED WIRE FABRIC (PRECAST) OR 2" COVER FOR DEFORMED BARS (CAST IN PLACE). ON BASE, REINFORCEMENT SHALL BE AS SHOWN ON STD MD 374.61-01 WITH 1 1/2" COVER (PRECAST) AND 2" COVER (CAST IN PLACE) FROM TOP OF BASE.
5. A CONCRETE OR BRICK CHANNEL WHICH SLOPES AT LEAST 2 IN./FT TOWARD THE OUTLET SHALL BE PROVIDED IN THE FIELD.
6. GRADE AND SLOPE ADJUSTMENTS SHALL BE COMPLETED IN THE FIELD USING PRECAST ADJUSTMENT COLLAR AND MORTAR.
7. SLOPED TROUGH FLOOR TO BE CAST IN THE FIELD AND USED ONLY WHEN ROAD GRADE IS 1.5% OR LESS. WHEN SLOPED TROUGH FLOOR IS USED, ROUGHEN PRECAST TROUGH FLOOR.
8. PRECAST INLET JOINTS-THE MANUFACTURER SHALL FORM MALE AND FEMALE ENDS OF JOINTS USING THEIR OWN DESIGN. THE JOINTS SHALL BE SEALED BY THE CONTRACTOR AND MADE WATERTIGHT USING THE MANUFACTURER'S RECOMMENDED ASTM OR AASHTO APPROVED SEALANT.
9. LADDER RUNGS SHALL BE PLACED IN VERTICAL ALIGNMENT AT 1'-3" C/C. RUNGS ARE INCIDENTAL TO THE COST OF THE INLET.
10. ANGLE IRON AND SHEAR STUD CONNECTORS SHALL BE GALVANIZED AFTER WELDING IN ACCORDANCE WITH ASTM A 123. SEE STDS. MD 374.55 & MD 374.64.
11. SEE STANDARD MD 374.65 FOR DEPRESSED GUTTER PAN.
12. SEE STANDARD MD 374.64 FOR ALTERNATE PRECAST COS TROUGHS.
13. PAY MEASUREMENTS FOR CAST IN PLACE UNIT SHALL BE THE SAME AS THE PRECAST UNIT. REFER TO NOTE 14. ALL OTHER DIMENSIONS SHOWN FOR PRECAST UNIT SHALL APPLY TO CAST IN PLACE UNIT.
14. MINIMUM DEPTH PAYMENT PER EACH SHALL BE 6'-2" MEASURED FROM THE PIPE INVERT TO THE TOP OF THE TROUGH SLAB. VERTICAL DEPTH PAYMENT PER LINEAR FOOT SHALL INCLUDE ALL DEPTHS IN EXCESS OF 6'-2" INCLUDING ALL APPURTENANCES.
15. PRECAST BASE UNIT WALLS MAY TAPER PER MANUFACTURER'S DESIGN.
16. FROM CURB LINE, INLET HAS BEEN DESIGNED FOR HS-25 LOADING, ACCORDING TO AASHTO LFRD BRIDGE DESIGN SPECIFICATIONS.

INLET TYPE	T	L
COS-5	5'-0"	6'-0"
COS-10	10'-0"	11'-0"
COS-15	15'-0"	16'-0"
COS-20	20'-0"	21'-0"

SPECIFICATION **305** CATEGORY CODE ITEMS

APPROVED *[Signature]*  
DIRECTOR - OFFICE OF HIGHWAY DEVELOPMENT

APPROVAL • SHA REVISIONS	APPROVAL • FEDERAL HIGHWAY ADMINISTRATION
APPROVAL 2-22-91	APPROVAL 1-2-91
REVISED 8-3-10	REVISED 7-26-10
REVISED 10-7-14	REVISED 9-29-14
REVISED -	REVISED -

**SHA** State Highway Administration

**Maryland Department of Transportation**  
**STATE HIGHWAY ADMINISTRATION**  
STANDARDS FOR HIGHWAYS AND INCIDENTAL STRUCTURES  
**PRECAST OR CAST IN PLACE**  
**SQUARE AND RECTANGULAR COS INLETS**  
5', 10', 15' & 20'

**STANDARD NO. MD 374.61**