

TEMPORARY TRAFFIC CONTROL TYPICAL APPLICATION

VEHICLE CONSPICUITY (STRIPING/LIGHTING) REQUIREMENTS

NOTES:

- ADEQUATE LINE OF SIGHT*(SIGHT DISTANCE) DURING MOBILE OPERATION IS NECESSARY FOR THE EFFECTIVE PERFORMANCE OF THESE VEHICLES CONSPICUITY REQUIREMENTS. IN CASE OF LIMITED LINE OF SIGHT A LANE/SHOULDER SHOULD BE CLOSED TO PROTECT THE VEHICLE ACCORDING TO THE APPROPRIATE TTC STANDARD.
- ALL WORK VEHICLES THAT ARE NOT PART OF THE MOBILE OPERATION AND ARE NOT PROTECTED BY CHANNELIZING DEVICES/BARRIER, SHALL ALSO DISPLAY FLASHING LIGHTS AND RETROREFLECTIVE STRIPING.
- FOR PERIODS < 15 MINUTES, VEHICLES MAY BE IN CLEAR ZONE, PROVIDED FLASHING LIGHTS ARE ON AND RETROREFLECTIVE STRIPING IS PRESENT.

STRIPING NOTES:

- ALL WORK VEHICLES SHALL HAVE SPECIFIED RETROREFLECTIVE STRIPES.
- HIGH PERFORMANCE WIDE ANGLE RETROREFLECTIVE SHEETING-VEHICLE MARKING TAPE STRIPE WIDTH - 2 INCH MINIMUM.

LIGHTING NOTES:

- BAR AND DOME LIGHTS SHALL BE CLASS I, AS DEFINED BY THE SOCIETY OF AUTOMOTIVE ENGINEERS (SAE).
- TO DETERMINE VEHICLE SPECIFIC LIGHTING, SEE MD 104.01-18B FOR VEHICLE LIGHTING SELECTION CHART.
- VEHICLE MAY ALSO DISPLAY FLASHING HAZARD/PARKING LIGHTS IN FRONT AND REAR.
- WHILE USE OF AMBER LIGHTS IS MANDATORY, SUPPLEMENTING AMBER LIGHTS WITH GREEN LIGHTS IS OPTIONAL AND IS RESERVED FOR HIGHWAY MAINTENANCE VEHICLES WHILE IN USE FOR SNOW REMOVAL OR PROTECTION OF HIGHWAY MAINTENANCE WORKERS. SEE 104.01-18B FOR DEPLOYMENT DETAILS.
- IF USED, GREEN LIGHTS SHALL BE USED TOGETHER WITH AMBER LIGHTS IN AN ALTERNATING PATTERN AND THE NUMBER OF GREEN LIGHTS SHALL NOT EXCEED THE NUMBER OF AMBER LIGHTS EQUIPPED AND DISPLAYED.

* SEE GENERAL NOTES DEFINITION.

EXAMPLE OF VEHICLE CONSPICUITY STRIPING/LIGHTING ON A WORK VEHICLE

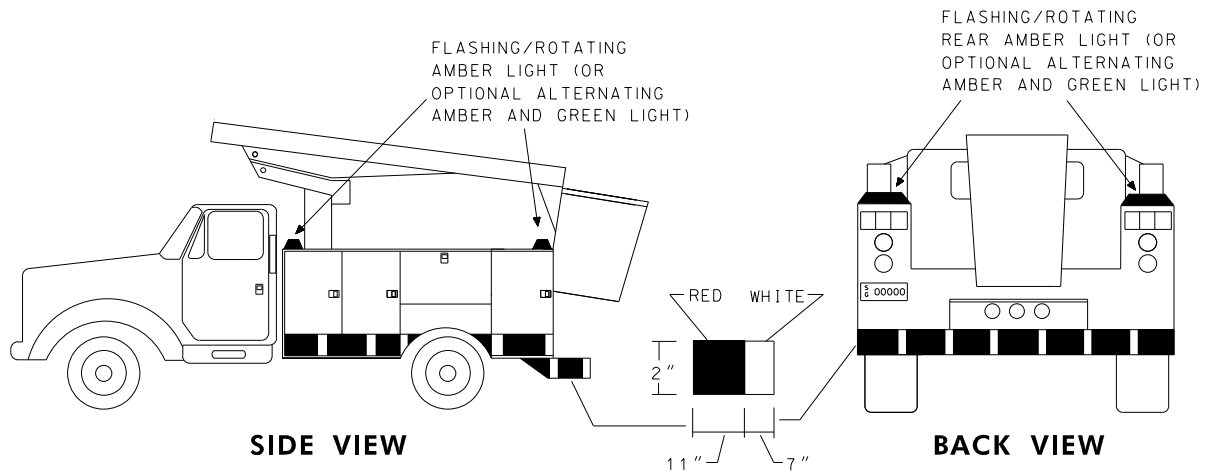

EXAMPLE OF PORTABLE TRAILER VEHICLE CONSPICUITY STRIPING

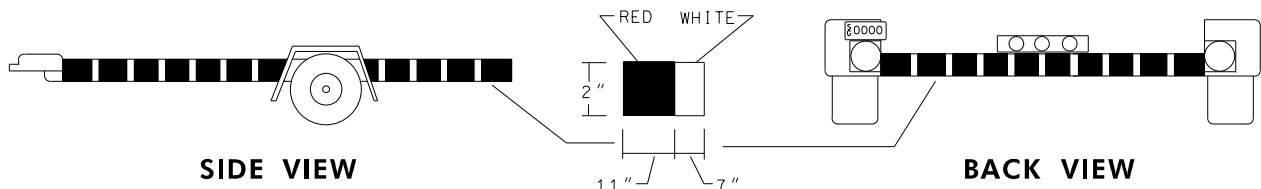

SPECIFICATION	CATEGORY CODE ITEMS		
APPROVED	<i>Cedric Wall</i> DIRECTOR - OFFICE OF TRAFFIC AND SAFETY		
APPROVAL REVISIONS	SHA	FEDERAL	ADMINISTRATION
APPROVAL	7-1-09	APPROVAL	7-27-09
REVISED	8-20-14	REVISED	8-11-14
REVISED	2-19-24	REVISED	12-06-23
REVISED		REVISED	

MOT MARYLAND DEPARTMENT OF TRANSPORTATION
STATE HIGHWAY ADMINISTRATION

STANDARDS FOR HIGHWAYS AND INCIDENTAL STRUCTURES

VEHICLE CONSPICUITY AND LIGHTING

STANDARD NO. MD 104.01-18A