

**PLAN**

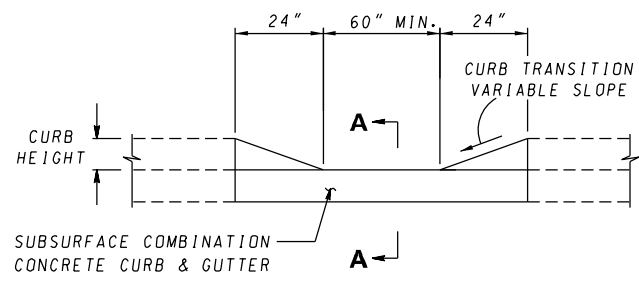

**ELEVATION**

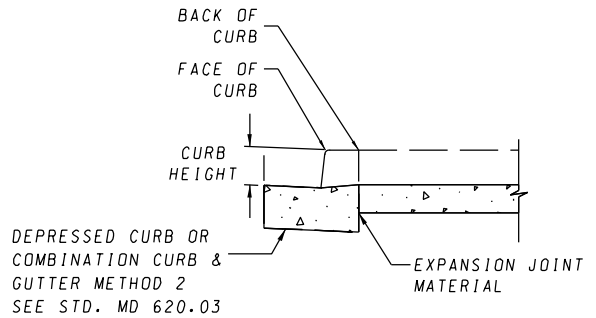

**SECTION A-A**

**NOTES**

1. TO BE USED WHERE A STREET-LEVEL PEDESTRIAN CROSSING IS REQUIRED THROUGH RAISED MEDIANS OR RAISED ISLANDS AND THERE IS INSUFFICIENT WIDTH TO PROVIDE A RAMPED MEDIAN OR ISLAND OPENING (STD. MD-655.22).
2. EXPANSION JOINT MATERIAL SHALL BE INSTALLED IN ACCORDANCE WITH STANDARD MD-655.01.
3. CUT-THROUGH MEDIAN AND ISLAND OPENINGS TO BE SHOWN ON PLANS SYMBOLICALLY AND REFERENCED WITH THE CENTER OF THE OPENING ALIGNED TO A STATION ON THE CONSTRUCTION CENTERLINE. SEPARATE DETAILS SHALL BE SHOWN WHERE PROPOSED OPENING VARIES FROM STANDARD METHODS.
4. WHERE 60" CUT THROUGHS CAN NOT BE PROVIDED A DESIGN WAIVER MUST BE REQUESTED.

SPECIFICATION <b>603 &amp; 611</b>	CATEGORY CODE ITEMS	
APPROVED	DIRECTOR - OFFICE OF HIGHWAY DEVELOPMENT	
	APPROVAL • SHA REVISIONS	APPROVAL • FEDERAL HIGHWAY ADMINISTRATION
	APPROVAL <b>2-10-04</b>	APPROVAL <b>3-31-04</b>
	REVISED <b>6-2-14</b>	REVISED <b>5-20-14</b>
	REVISED	REVISED
	REVISED	REVISED

**Maryland Department of Transportation**  
**STATE HIGHWAY ADMINISTRATION**  
 STANDARDS FOR HIGHWAYS AND INCIDENTAL STRUCTURES  
  
**CUT-THROUGH**  
**MEDIAN AND ISLAND OPENINGS**  
  
**STANDARD NO. MD 655.21**