

ELEVATION B-B

NOTES

1. THE JUNCTION BOXES SHALL BE LOCATED EVERY 500 FEET, AS SHOWN ON THE PLANS, OR AS DIRECTED BY THE ENGINEER.
2. THE COST OF THE CONDUITS, JUNCTION BOXES, AND APPURTENANCES SHALL BE INCIDENTAL TO THE COST OF THE BARRIER UNLESS OTHERWISE SPECIFIED.
3. IN INSTANCES WHERE THE BARRIER CONNECTS TO A BRIDGE PARAPET CONTAINING CONDUIT, THE CONDUITS SHALL TRANSITION TO ALIGN WITH THE BRIDGE CONDUITS.
4. CAP CONDUIT FOR FUTURE USE OR CONNECT TO JUNCTION WELL PER LIGHTING PLANS.
5. REFER TO SECTION 805 FOR CONDUIT, ETC.
6. CONDUIT SHALL EXIT CONCRETE BARRIER USING CONDUIT BENDS AND SWEEPS, NOT BY EXITING THROUGH THE BOTTOM OF THE JUNCTION BOX.
7. JUNCTION BOXES SHALL BE GALVANIZED STEEL WITH COVERS MOUNTED IN THE FRONT OF THE CONCRETE BARRIER. FACE OF COVER SHALL BE FLUSH WITH FACE OF CONCRETE BARRIER. COVER SHALL BE 1/4" THICK GALVANIZED STEEL.
8. PIPE AND EXPANSION FITTINGS SHALL BE U.L. APPROVED FOR ENCASEMENT IN CONCRETE.
9. JUNCTION BOXES SHALL HAVE 1/2" DIA. HOLES AT LOW POINT OF JUNCTION BOX. INSTALL 1/2" DIA. DRAIN PIPE AT LOW POINT AND OUTLET AT BACK OF BARRIER.
10. JUNCTION BOX COVERS SHALL INCLUDE TAMPER RESISTANT BOLTS.
11. CUT VERTICAL AND HORIZONTAL BARS IN CONFLICT WITH JUNCTION BOX AND REINFORCE AROUND BOX AS SHOWN ON STANDARD NO. MD 648.50-04. EPOXY TOUCH UP CUT BARS.
12. PLACE PVC EXPANSION COUPLING AT BARRIER EXPANSION JOINTS.

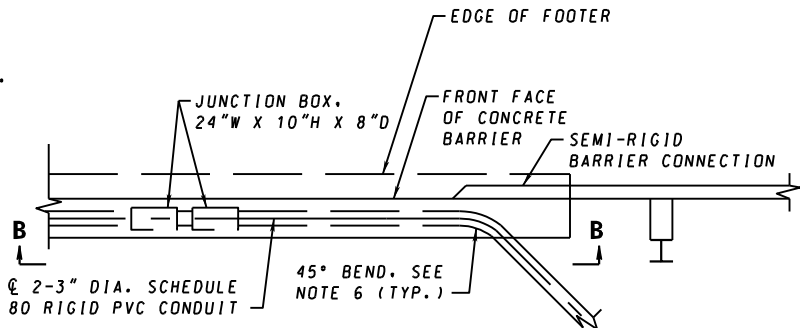

PARTIAL PLAN

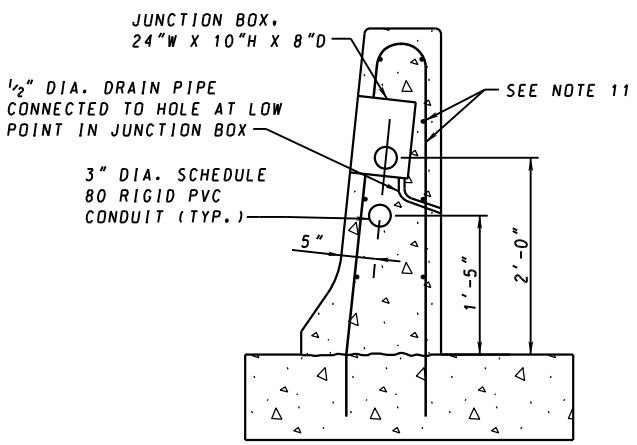

SECTION A-A

CONDUIT LAYOUT AT UPPER JUNCTION BOX. LAYOUT AT LOWER JUNCTION BOX SIMILAR

SPECIFICATION 604	CATEGORY CODE ITEMS
APPROVED	<i>Charles P. ...</i> DIRECTOR - OFFICE OF HIGHWAY DEVELOPMENT
APPROVAL SHA REVISIONS	APPROVAL FEDERAL HIGHWAY ADMINISTRATION
APPROVAL 3-1-01	APPROVAL 3-28-01
REVISED 10-1-01	REVISED
REVISED 6-27-23	REVISED 6-21-23
REVISED	REVISED

MDOT MARYLAND DEPARTMENT OF TRANSPORTATION
STATE HIGHWAY ADMINISTRATION

**STANDARDS FOR HIGHWAYS AND INCIDENTAL STRUCTURES
CONDUIT AND JUNCTION BOX LOCATION FOR
34 INCH AND 42 INCH F SHAPE CONCRETE
TRAFFIC BARRIER SINGLE FACE**

STANDARD NO. MD 648.50