

RETENTION DISK

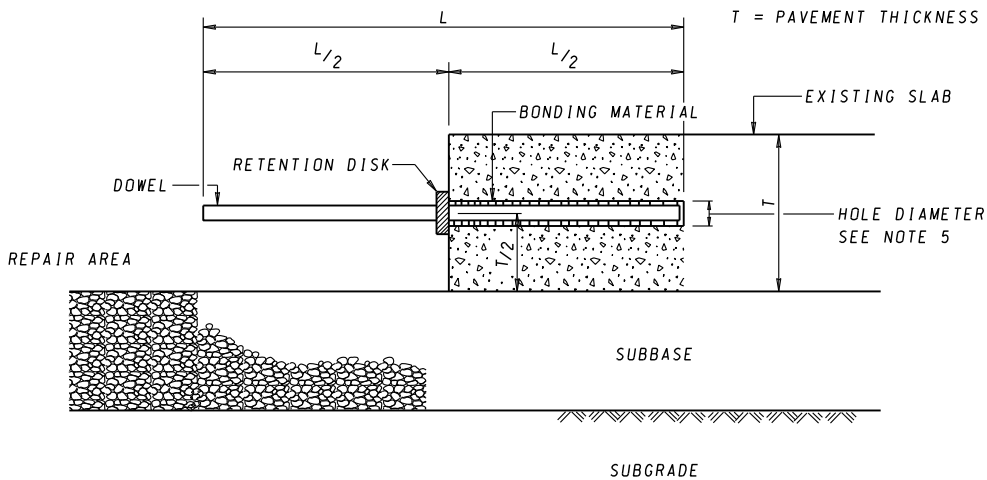

TYPICAL ELEVATION VIEW

NOTES

1. COST OF THE DOWEL, DRILLED HOLES, RETENTION DISK, BONDING MATERIAL, ALL EQUIPMENT, TOOLS, AND LABOR SHALL BE INCIDENTAL TO THE RESPECTIVE TYPE 1 OR 2 REPAIR PAY ITEM IN THE INVITATION FOR BIDS.
2. BONDING MATERIAL PER 902.11. SEE NOTE 5.
3. SEE STANDARD MD 572.21 FOR LENGTH.
4. ALL DOWELS AND CHAIRS SHALL BE EPOXY COATED.
5. IF NONSHRINK GROUT WILL BE USED, DIAMETER SHALL BE 0.2" TO 0.25" LARGER THAN LOAD TRANSFER DEVICES. IF A DIFFERENT MATERIAL WILL BE USED, DIAMETER SHALL BE IN ACCORDANCE WITH MANUFACTURER'S RECOMMENDATIONS AND APPROVED BY THE ENGINEER.

SPECIFICATION 522	CATEGORY CODE ITEMS
APPROVED	<i>Raff</i> DIRECTOR - OFFICE OF HIGHWAY DEVELOPMENT
	APPROVAL • SHA REVISIONS
	APPROVAL 4-18-90
	REVISED 2-25-16
	REVISED
APPROVAL • FEDERAL HIGHWAY ADMINISTRATION	APPROVAL 6-8-90
	REVISED 2-23-16
	REVISED
	REVISED

Maryland Department of Transportation
STATE HIGHWAY ADMINISTRATION
 STANDARDS FOR HIGHWAYS AND INCIDENTAL STRUCTURES

**DOWEL ANCHORAGE FOR
 TYPE 1 AND TYPE 2 PAVEMENT REPAIRS**

STANDARD NO. MD 577.08